

Steca Solarix 2020-x2

The Steca Solarix 2020-x2 is a state-of-the-art dual battery charge controller that is ideal for use in leisure and caravan applications. It is equipped with a solar module input suitable for all 72-cell crystalline solar modules in 24 V systems and for all 36-cell crystalline solar modules in 12 V systems. Both main battery and starter battery are charged simultaneously and continuously by the solar module. 90 percent of the available power flows into the main battery while 10 percent of the power is retained to keep the auxiliary battery fully-charged.

The charge power split can be adapted using the Steca PA LCD1 remote display. The charge controller is equipped with a high-power load output fed by the main battery only. The charge controller has a USB charge socket, which can be used to charge smartphones and tablets. Connection of the Steca PA LCD1 remote display is optional.

CLASSIC



Quality made in Germany

Product features

- Series controller
- Automatic detection of voltage
- Voltage and current regulation
- PWM control
- Multistage charging technology
- Current compensated load disconnection
- Automatic load reconnection
- Temperature compensation
- Positive earthing of one or negative earthing of several terminals possible
- Integrated self test
- Monthly maintenance charge
- USB charge socket for smartphones and tablets

Interfaces

- StecaLink Bus

Electronic protection functions

- Overcharge protection
- Deep discharge protection
- Reverse polarity protection of module (≤ 36 V), load and battery
- Automatic electronic fuse
- Short circuit protection of load and module
- Open circuit protection without battery
- Reverse current protection at night
- Overtemperature and overload protection
- Load disconnection on battery overvoltage

Displays

- 4 LEDs show operating states

Options

- Connection of PA LCD1 remote display possible

Certificates

- Compliant with European Standards (CE)
- RoHS compliant
- Made in Germany
- Developed in Germany
- Manufactured according to ISO 9001 and ISO 14001

Steca accessories

- Remote display Steca PA LCD1

20 A

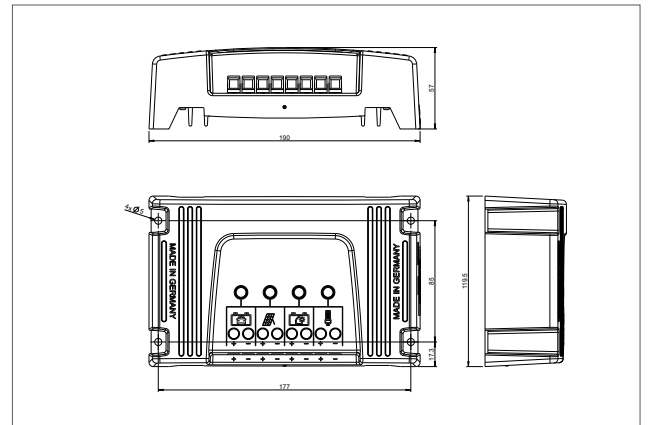
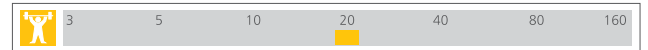

Steca Solarix 2020-x2	
Characterisation of the operating performance	
System voltage	12 V (24 V)
Own consumption	22 mA
DC input side	
Open circuit voltage solar module	< 60 V
Module current	20 A
DC output side	
Load current	20 A
USB charge socket	5 V / 2.5 A
Reconnection voltage (LVR)*	12.5 V
Deep discharge protection (LVD)*	11.7 V
Battery side	
End of charge voltage*	14.1 V (28.2 V)
Boost charge voltage*	14.4 V (28.8 V)
Equalisation charge*	15 V (30 V)
Set battery type*	gel
Main/auxiliary battery charging ratio	90 % / 10 %
Operating conditions	
Ambient temperature	-10 °C ... +60 °C
Fitting and construction	
Terminal (fine / single wire)	6mm ² / 10mm ² - AWG 10 / 8
Degree of protection	IP 31
Dimensions (X x Y x Z)	190 x 120 x 57 mm
Weight	500 g

* adjustable via Steca PA LCD1

Technical data at 25 °C / 77 °F

Key:

- A Solar modules
- B Solar charge controller Steca Solarix 2020-x2
- H Batteries
- L Electrical load

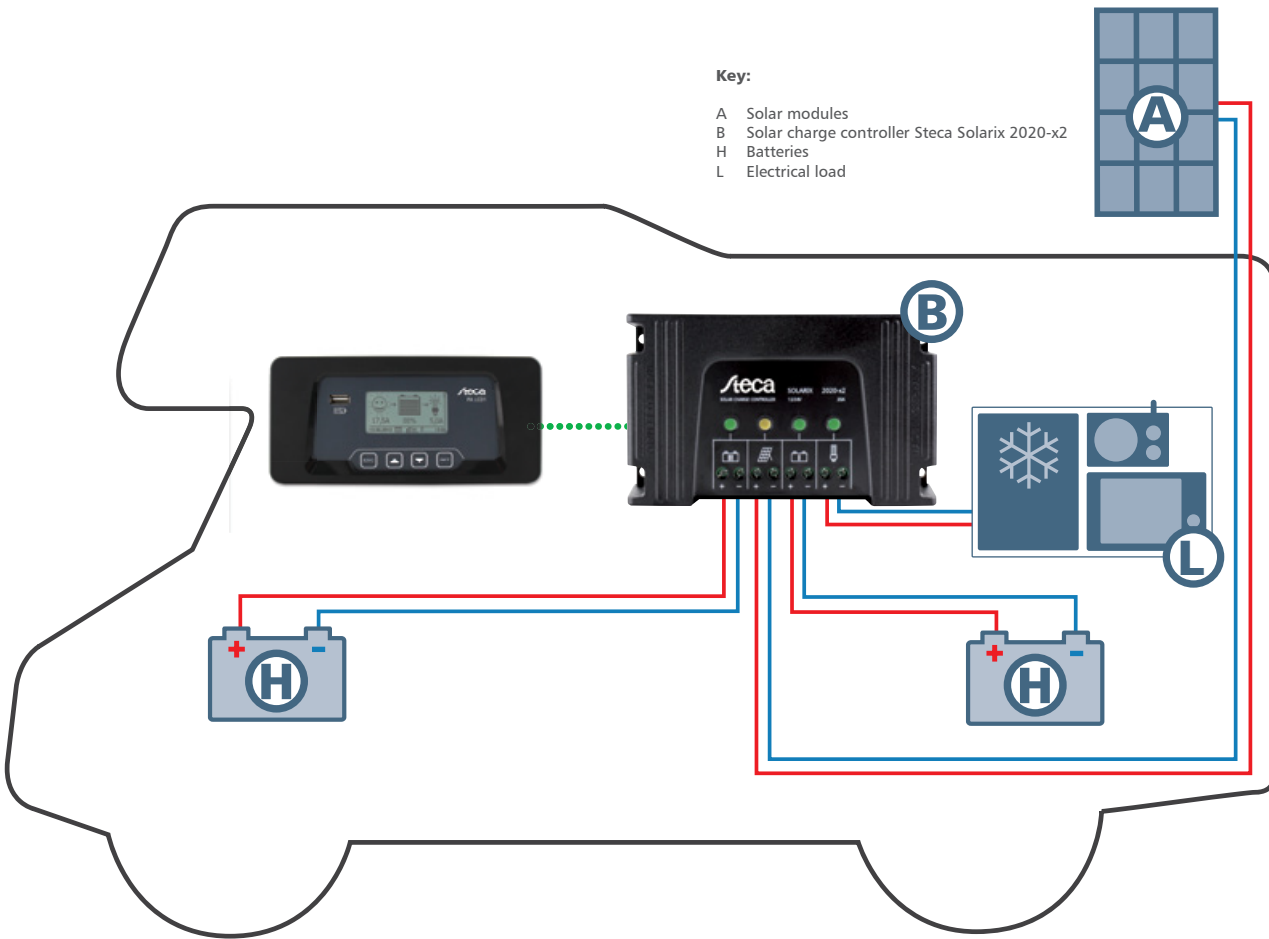

The innovative dual battery charge controller with remote display is particularly appealing for recreational and motorhome sector applications with high demands around professional battery management and visual appearance in the visible part of the recreational vehicle. These devices are also ideal for similar applications in the boating sector.

Numerous application options exist for the dual battery charge controller aside from the recreational market: any small to medium-sized stationary PV system designed to charge two independent batteries via one module field represents a potential application for the controller.



Overview of devices:

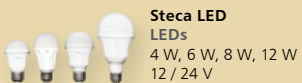

Steca LED LEDs
4 W, 6 W, 8 W, 12 W
12 / 24 V



Steca Solsum ESL
Energy-saving lights
5 W, 7 W, 11 W / 12 V



Steca PF 166
Solar refrigerator / freezer
12 / 24 V



Steca PA LCD1
Remote display